

Mobility Corral

Public • Dockless • On-Street • Configurable • Cost-effective



High quality roadway cycle parking with a range of configuration options and fast, cost-effective deployment.

The Mobility Corral is designed to quickly re-allocate street space for cycle parking; providing twelve protected spaces in the same footprint as a standard car parking space. With robust racking arranged for bikes to be locked at the frame and the wheels, it fosters a tidy street

environment by reducing ad-hoc parking against railings and other street furniture.

Ideal for regular bikes and dockless rental schemes alike, the modular construction can be configured for compact six space enclosures through to larger mixed use installations. Further customization is available with integrated signage and planters.

Key features

- Fits twelve cycle spaces in one car space
- Flexible design suits range of micromobility types
- Made using high-quality recyclable materials
- Modular for easy transport, quick installation and scalability
- More cost-effective than traditional methods
- Minimal ground fittings enables quick and easy redeployment
- Protects users and cycles from traffic
- Integrated high level signage
- Wheels and frame lock to the cycle rack
- Reflective panels increase visibility for all road users
- Durable finish protects bikes from scratches
- Elevated internal racks allows street cleaning
- Designed in the UK
- Manufactured in the US

Product options

- Rackless for various mobility types
- Compact six space module for small sites
- Custom branded front panels
- End planters
- Also available: Cargo Corral for cargo bikes



Form factor



Clean, modern design for a tidy streetscape

Finished in a durable grey nylon powder coat, the Mobility Corral's robust steel frame blends seamlessly into the streetscape.

When empty, the enclosure has a low visual impact, when in use it brings order to parked bikes and reduces street clutter. Reflective trim ensures the boundaries of the corral are visible to all road users in low light conditions.

At 17 feet wide, the twelve space standard configuration fits in the footprint of a regular car parking space; ideal for roadway installation.

The six-space single module stands at 8' 5". The optional planters add greenery, color and a premium appearance.

Dimensions

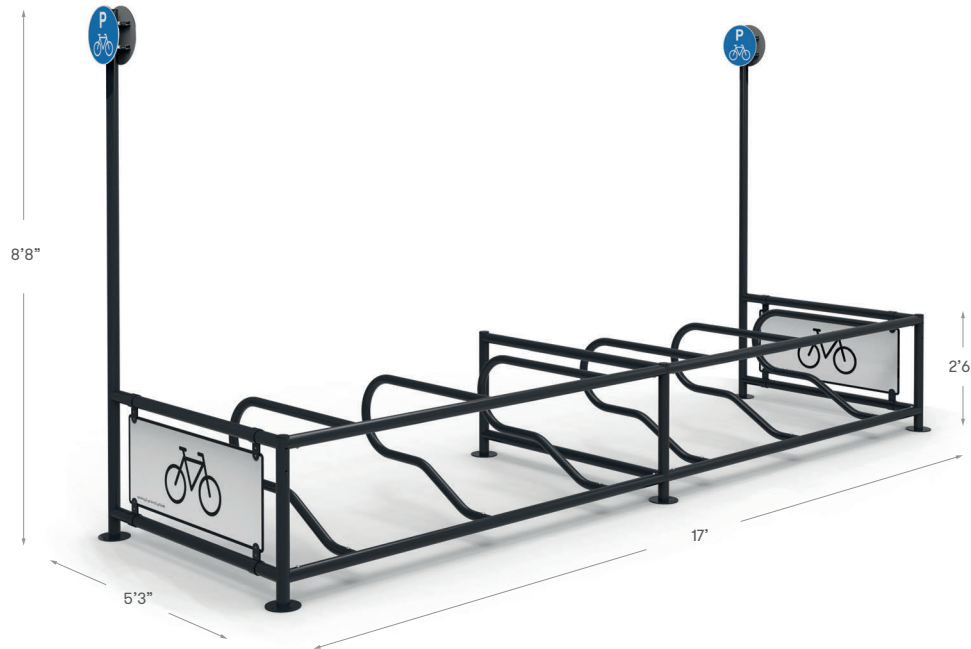

Twelve space standard unit

With racking provision for twelve bikes, the standard unit is perfect for popular cycle journey destinations such as shopping precincts, leisure facilities, stations and education centers.

Additional six space modules can be included, each adding 8'4" to the overall width. The extra capacity is ideal for high volume locations such as dockless rental hubs.

Six space single module unit

With a compact 8'5" width, the six space single unit fits easily into a wide range of scenarios.

With its fast deployment process and easily recognizable signage, it is ideal for creating a network of parking locations for dockless bike rental schemes and regular cycles alike.

The modular construction ensures that each unit can be expanded to meet demand.

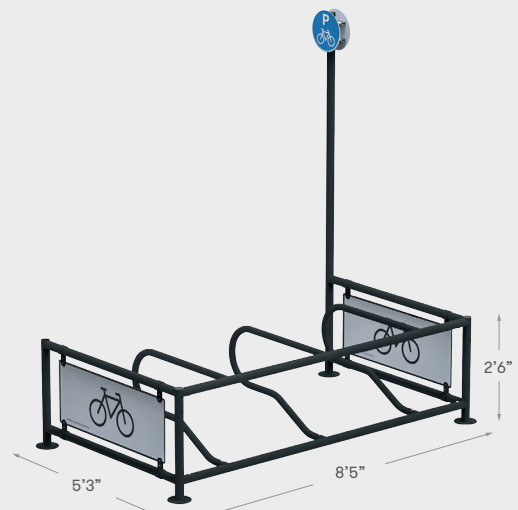

Rackless single module for e-scooter rental schemes



Rackless twelve space unit for mixed use

In use



Secure, easy roadway parking

The Mobility Corral offers clear advantages over simple road-marked boundaries and built-out parking options. When installed on the roadway, it creates a physical barrier to separate bikes from other road users, helping prevent damage from falls or vehicle strikes. The user is protected by the frame while parking and locking their bike. The racking is shaped to facilitate secure three point locking; bikes can be locked by the frame and both wheels.

When installed adjacent to the curb, the frame is positioned to provide 70 inches of clearance to accommodate bikes with longer wheelbases.

The floating rack arrangement and minimal ground fixings allow Corrals to be relocated, expanded or reconfigured to meet changes in demand.

High level reflective signage makes each Corral visible from a distance. Optional signage panels create space for branding or instructional content; ideal for promotion and rental schemes.



Service options



Delivery and installation US-wide

Mobility Corrals can be delivered partially assembled where access allows, or can be built on site where access is restricted.



Flat-pack delivery worldwide

We offer global delivery of our Mobility Corrals. They come flat-packed for cost-effective shipping, with easy to follow assembly documents.